

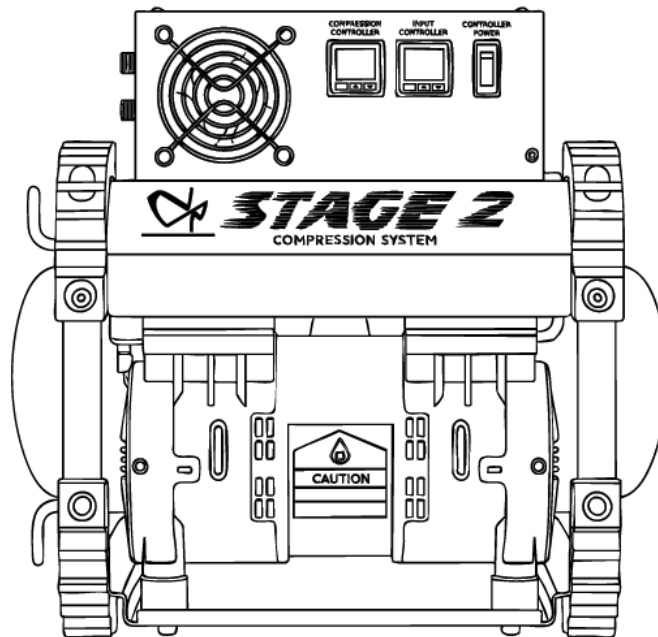

# STAGE 2 PRO COMPRESSION SYSTEM

Digital Properties Group Inc

[dpgsupply.com](http://dpgsupply.com)



# INDEX

---







Section	Page
Index	1
Package Contents	2
Components	3
Installation Guide	4
Pre-Vent User Guide	8
Re-Active Tech User Guide	9
Threshold Pressure Setting	10
Safety	11
Troubleshooting	13
Warranty	16

## **CAUTION!**

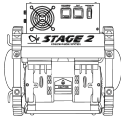
**Before operation of this compression system read this manual and follow all Safety Rules and Operation Instructions. Retain this manual for Future Reference.**

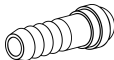
# PACKAGE CONTENTS

---

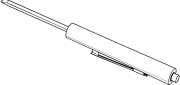
Name		Part No.	Qty.
Stage 2 Pro		STAGE2-PRO-1	1
CGA 1/4" Barb		P220601	3
CGA 5/16" Barb		P270601	3
CGA 3/8" Barb		P230601	3
CGA RH Nut		P260001	3
Alternate Adjustable PRV Springs		-	3
CGA 11/16 Nut Wrench		M90000	1
Pre-Vent Adjustment Screw Driver		M900001	1

# COMPONENTS

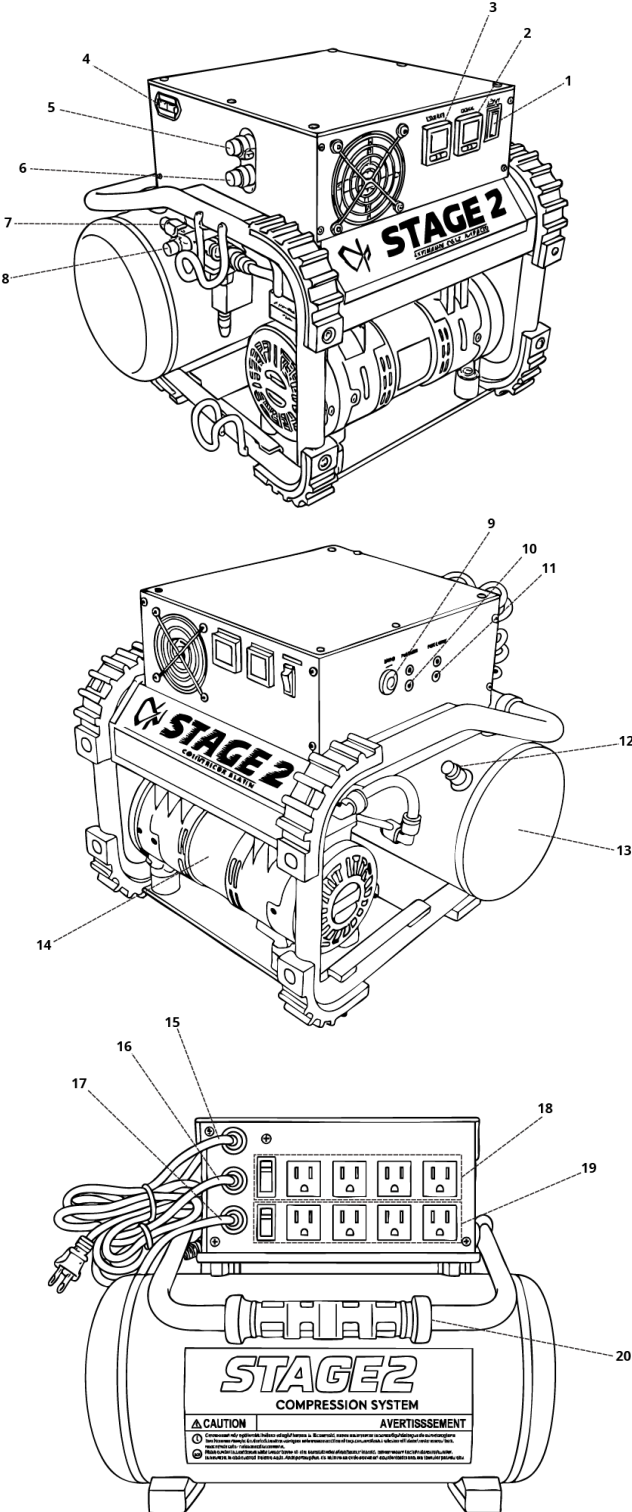

1. Control Power Switch
2. Input Controller
3. Compression Controller
4. Hour Meter
5. Low Pressure Input A
6. Low Pressure Input B
7. High Pressure Safety Relief Valve
8. High Pressure Output
9. Pre-Vent Bypass Switch
10. Pre-Vent A Time Delay Settingmn
11. Pre-Vent B Time Delay Setting
12. Low Pressure Variable Relief Valve
13. Low Pressure Buffer Tank
14. Compressor
15. Control Power Cord
16. Bank A Power Cord
17. Bank B Power Cord
18. Bank A Power Switch and Outlets
19. Bank B Power Switch and Outlets
20. Carry Handle

# INSTALLATION GUIDE

---

⚠ **WARNING:** Read this guide carefully before installing and operating the Stage 2 Oxygen Compression System. Failure to follow these instructions may result in serious injury, fire, equipment damage, or voiding of the warranty.

---

## 1. Installation Location Requirements

To ensure safe operation and optimal performance, install the system in a suitable environment:

- Cool, Dry Space** – Install in an area free from excessive humidity, moisture, or water exposure. Exposure to high humidity or water will void the compressor warranty.
  - Well-Ventilated Area** – Ensure proper airflow around the unit to prevent overheating and allow safe oxygen dispersion.
  - Away from Ignition Sources** – Keep at least 10 feet (3 meters) away from open flames, sparks, or heat sources such as:
    - Gas-powered appliances
    - Open flames (candles, stoves, lighters)
    - Electrical panels or high-heat equipment
  - Stable, Level Surface** – Place the unit on a sturdy, level surface to prevent vibration, movement, or tipping.
- 

## 2. Electrical Connection

⚠ **WARNING:** This device operates on 120V AC power. Improper connection may cause electrical shock, fire, or damage to the unit.

- Use dedicated 120V AC outlets with sufficient capacity for the compressor’s and/or the concentrators power draw.
- Do not use extension cords, power strips, or adapters—plug the unit directly into properly grounded outlets.
- Ensure the power cords are free from damage and kept away from heat, sharp objects, and moving parts.
- If the power cords become damaged, disconnect power immediately and replace before use.

### 3. System Setup & Connection

1. Position the Compressor – Place the system in the designated location, ensuring proper clearance on all sides for airflow and maintenance.
2. Group and install Oxygen Concentrators – Separate Bank A concentrators and Bank B concentrators.

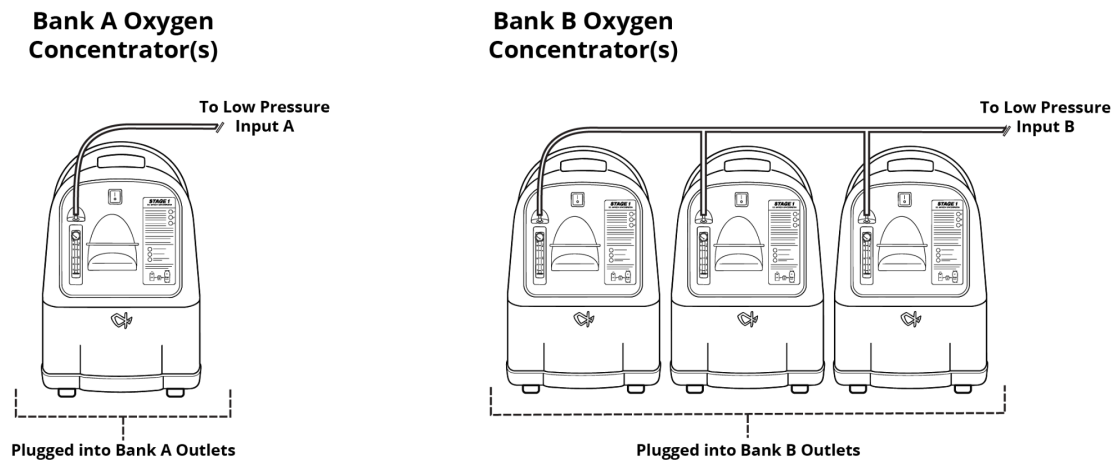

- Plumb the outputs of Bank A together and into Input A. Plug these concentrators into any of the 4 Bank A power outlets on the rear panel.
- Plumb the outputs of Bank B together and into Input B. Plug these concentrators into any of the 4 Bank B power outlets on the rear panel.
  - i. Use only approved high-pressure oxygen-rated hoses and fittings. Ensure all connections are secure and free of leaks.

3. Turn all Concentrators Manual Power switches to the ON position.
  - This will not power them on just yet. This simply allows the Stage 2 to power them on and off automatically.
4. Check that all Oxygen Concentrators are connected to the correct inputs and power sources. Warning: Failure to do so may result in damage to the Oxygen Concentrator(s).
  - Oxygen Concentrators powered by Bank A feed oxygen supply to Input A.
  - Oxygen Concentrators powered by Bank B feed oxygen supply to Input B.
5. Connect a High Pressure Storage tank rated above 150 psi to the High Pressure Outlet.
6. Verify Power Supply – Confirm that the electrical outlet is properly grounded and meets the 120V AC power requirement.
7. Plug in the Unit – Insert the 3 power plugs securely into grounded outlets.
  - Controller - Supplies power to the compressor and controllers.
  - A - Supplies power to Bank A outlets.
  - B - Supplies power to Bank B outlets.
8. Power On & Test – Power on the Bank A and Bank B power switches on the rear panel followed by the Controller power switch on the front panel.
  - The Stage 2 Compression system should immediately power on concentrators and begin venting impure oxygen by default.
  - Wait 3 minutes for the system to begin compressing or activate the Pre-Vent Bypass Switch.
9. Check for Leaks – Apply an oxygen-compatible leak detection solution to all fittings. Do not use an open flame to check for leaks.
10. Monitor for normal operation – Ensure pressure levels are within safe operating limits.

Note: The first fill can trap air impurities. To remove them, vent the High Pressure Tank at its bottom before repressurizing.

---

## 4. Important Safety Warnings

- ✗ DO NOT install in an enclosed or unventilated space—oxygen buildup can create a fire hazard.
  - ✗ DO NOT expose to water, rain, or high humidity—this will void the compressor warranty.
  - ✗ DO NOT modify or tamper with electrical components—doing so may result in shock or fire.
  - ✗ DO NOT exceed the system's rated pressure limits—over-pressurization may cause failure.
  - ✗ DO NOT use oil, grease, or petroleum-based lubricants on oxygen fittings—these can ignite explosively.
  - ✓ Always use manufacturer-approved components and accessories.
  - ✓ Regularly inspect hoses, fittings, and power connections for signs of wear or damage.
  - ✓ If a leak, electrical issue, or unusual noise occurs, shut down the system immediately and inspect before further use.
- 

## 5. Final Checklist Before Operation

- ✓ Compressor is installed in a cool, dry, and ventilated area
  - ✓ Unit is at least 10 feet away from ignition sources
  - ✓ Power is plugged into a dedicated 120V AC grounded outlet
  - ✓ Oxygen hoses and fittings are properly connected and leak-tested
  - ✓ System operates normally without unusual noise or pressure fluctuations
- 

Following these installation guidelines will help ensure safe operation, longevity of the compressor, and compliance with warranty requirements. If you have any questions or need assistance, contact the manufacturer's support team before proceeding.

---

# PRE-VENT USER GUIDE

---

The Pre-Vent feature guarantees that only high-purity oxygen is stored by automatically venting any initial impurities when the oxygen concentrators start up. This process ensures that the system reaches optimal purity levels before directing oxygen to storage.

The Pre-Vent delay is set to 3 minutes by default for both Banks A & B.

For users who prefer to bypass this function, the Pre-Vent Bypass switch can be activated, allowing all oxygen—including the initial startup flow—to be stored without venting.

△ Note: Disabling the Pre-Vent feature may result in slightly lower initial oxygen purity levels upon startup.

---

## Adjusting the Pre-Vent Duration

- Reset to minimum: Use a small flathead screwdriver to turn the dial counterclockwise to the 1 o'clock position (0.1 min).
- Set desired duration: Turn the dial clockwise to match the time you want:

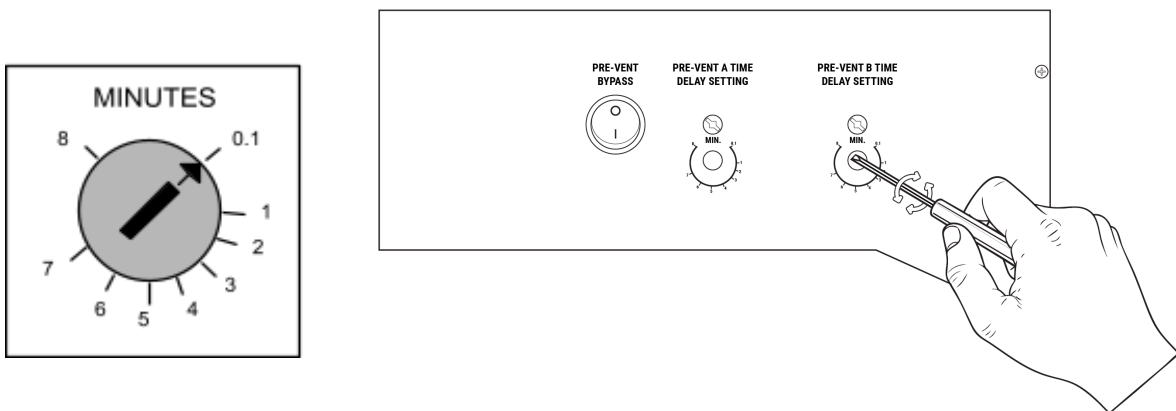

# RE-ACTIVE TECH USER GUIDE

---

The Re-active feature helps extend the life of your oxygen concentrators by optimizing their workload. It uses two concentrator banks:

- Bank A does most of the work.
- Bank B only turns on when oxygen demand is high.

This setup reduces frequent cycling, which can wear out concentrators faster. If you have fewer than 8 concentrators, place most of them in Bank B to minimize wear on individual units.

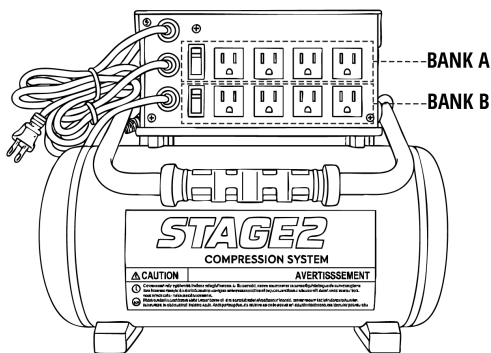

## How It Works (Default Settings)

The Stage 2 Compression System maintains a tank pressure of 105 psi. Here's what happens:

1. When tank pressure drops below 90 psi, Bank A starts refilling it.
2. If Bank A restores pressure to 105 psi, it shuts off.
3. If pressure keeps dropping below 65 psi, Bank B turns on to fill high demand.
4. Once pressure reaches 95 psi, Bank B turns off, and Bank A finishes topping off the tank to 105 psi.

## Compression Controller Default Threshold Pressure Settings:

- Lo - 1: -0.5 psi (Compressor turns off)
- Hi - 1: 4.0 psi (Compressor turns on)

## Input Controller Default Threshold Pressure Settings:

- Lo - 1: 90 psi (Bank A turns on)
- Hi - 1: 105 psi (Bank A turns off)
- Lo - 2: 65 psi (Bank B turns on)
- Hi - 2: 95 psi (Bank B turns off)

# THRESHOLD PRESSURE SETTINGS

---

While in operation you can adjust the output pressure settings of the controllers by following these steps:

1. Press the blue MODE button once to cycle through the available threshold pressure settings.
  - The display will briefly show the setting identifier, followed by the current threshold value.
2. Use the gray UP or DOWN arrow buttons to adjust the threshold value.
  - Press and hold the button to adjust values more quickly.
3. The controller remains in RUN mode while adjustments are made.



➔ Repeat these steps as needed to adjust different threshold settings.

## Available Threshold Pressure Settings

- Lo - 1 → Output 1 Low Threshold
- Hi - 1 → Output 1 High Threshold
- Lo - 2 → Output 2 Low Threshold
- Hi - 2 → Output 2 High Threshold

# SAFETY PRECAUTIONS

---

## Compressed Oxygen Safety

- Oxygen supports combustion. Keep away from flames, sparks, smoking materials, and flammable substances.
  - Never use oil, grease, or other petroleum-based substances near oxygen connections—these can ignite explosively.
  - Always use approved, high-pressure-rated hoses and fittings designed for oxygen service.
  - Regularly inspect for leaks using an oxygen-compatible leak detection solution—never use a flame to check for leaks.
  - Do not exceed the maximum rated pressure of the system.
  - Store and transport oxygen tanks/cylinders securely in an upright position, away from direct sunlight and extreme heat.
- 

## Electrical Safety

- Ensure the machine is properly grounded before use.
  - Only connect the unit to a power source that matches the voltage and frequency specified in the manual.
  - Do not use extension cords or power strips—plug the unit directly into a properly rated outlet.
  - Keep power cords away from heat, sharp objects, and moving parts.
  - Unplug the unit before performing maintenance or repairs.
  - If the unit or power cord becomes damaged, discontinue use immediately and contact a qualified technician.
-

## Operational Safety

- Never operate the machine in an enclosed or poorly ventilated space, as oxygen buildup can pose a fire hazard. Additionally, ensure sufficient airflow to prevent the risk of an oxygen-depleted environment.
  - Always ensure the attached vessel is rated for operating at above the set outlet pressure of the Stage 2 controller to prevent bursting. Verify safety blow off valves are adjusted according to your process requirements
  - Do not cover or obstruct ventilation openings.
  - Avoid overfilling oxygen storage tanks or exceeding pressure limits.
  - Regularly check and replace filters, hoses, and seals as recommended by the manufacturer.
  - If a leak, electrical issue, or unusual noise occurs, shut down the machine immediately and inspect before further use.
  - INSPECT SYSTEM REGULARLY. Rusted or otherwise damaged tank can cause explosion and severe or fatal injury. Utilize tank drain before long term storage.
- 

## Emergency Procedures

- In case of fire, shut off the oxygen supply only if safe to do so, and use a Class D fire extinguisher for metal fires or a Class B/C extinguisher for electrical fires.
  - If an oxygen leak is detected, shut down the machine and ventilate the area immediately.
  - In the event of an electrical shock, disconnect power at the breaker before assisting the affected person.
-

# TROUBLESHOOTING

---

## System Not Receiving Power

1. Verify Power Connections:
    - Ensure all three power supply cords are securely plugged into dedicated, grounded 120V 15A AC outlets.
    - Avoid using extension cords or power strips.
  2. Check Power Switches:
    - Confirm that all three power switches are turned ON:
      - Bank A Power Switch (rear panel)
      - Bank B Power Switch (rear panel)
      - Controller Power Switch (front panel)
    - These switches will illuminate when power is properly supplied.
  3. Inspect Power Cords:
    - Examine all power cords for signs of damage, fraying, or wear.
    - If any damage is detected, discontinue operation immediately and contact customer support.
- 

## Oxygen Concentrators Not Receiving Power

1. Verify Oxygen Concentrator Power State:
  - Each concentrator should be turned ON while plugged into the system.
  - Most concentrators have a manual power switch—ensure it is in the ON position.
2. Check Power Connections:
  - Confirm that both A and B power cords are securely plugged into a suitable power source and are undamaged.
3. Check Power Switches on the System:
  - Ensure all three power switches are turned ON:
    - Bank A Power Switch (rear panel)
    - Bank B Power Switch (rear panel)
    - Controller Power Switch (front panel)

- These switches will illuminate when power is properly supplied.
  - 4. Inspect Oxygen Concentrator Power Cords:
    - Check for any damage or wear. If found, discontinue use immediately and repair or replace the affected concentrator(s).
- 

## Holding Tank Pressure Not Maintained

1. Power Off the System:
    - Shut down the compression system before performing any checks.
  2. Check for Leaks:
    - Inspect the High-Pressure Storage Vessel and its connections to the High-Pressure Output for any leaks.
    - Examine all oxygen lines for cracks, loose fittings, or wear.
  3. Depressurize Before Repairs:
    - Before repairing leaks or replacing damaged oxygen lines, fully depressurize the system.
    - ⚠ WARNING: Never adjust fittings or lines while the system is pressurized—doing so may result in injury.
  4. Understand Pressure Variations:
    - Minor fluctuations in holding pressure are normal due to temperature changes.
- 

## Oxygen Concentrator Flow is Impeded

1. Power Off the System and Concentrator Banks.
  2. Verify Proper Installation:
    - Ensure the oxygen concentrators are correctly connected:
      - Bank A concentrators should feed oxygen into Input A.
      - Bank B concentrators should feed oxygen into Input B.
  3. Check Oxygen Lines:
    - Inspect all oxygen lines for kinks, blockages, or obstructions.
    - Ensure hoses are properly routed and free of bends that could restrict flow.
-

## Impurities Entering the Holding Tank

1. Monitor Oxygen Purity Warnings:
    - Some oxygen concentrators have a low purity warning light.
    - If this light remains illuminated while the system is compressing, adjustments to the Pre-Vent settings may be necessary.
  2. Account for External Factors:
    - Weather conditions, machine age, and other environmental factors can impact the duration of initial impurities during startup.
  3. Adjust Pre-Vent Settings:
    - Increasing the Pre-Vent duration can help eliminate more impurities before compression begins.
    - Refer to the Pre-Vent User Guide for detailed instructions on making adjustments.
-

# WARRANTY

---

The Stage 2 Compression System is backed by a limited manufacturers warranty, which includes the following coverage:

- 100% coverage for 150 hours of runtime (that's >75 Full K Tanks worth of Oxygen production) or 365 days from the date of purchase, whichever occurs first.
- After this period, coverage continues on a prorated basis. This is included under our Premium Protection Plan. Please contact us or see our website [dpgsupply.com](http://dpgsupply.com) for details.

For full warranty terms, conditions, and claim procedures, please refer to the warranty section of our website or contact our support team.

---